



JAKS STEEL INDUSTRIES SDN BHD

(A Member of JAKS GROUP)

Product Catalogue

Carbon Steel Butt-Welded Fittings

Precision Quality Fittings



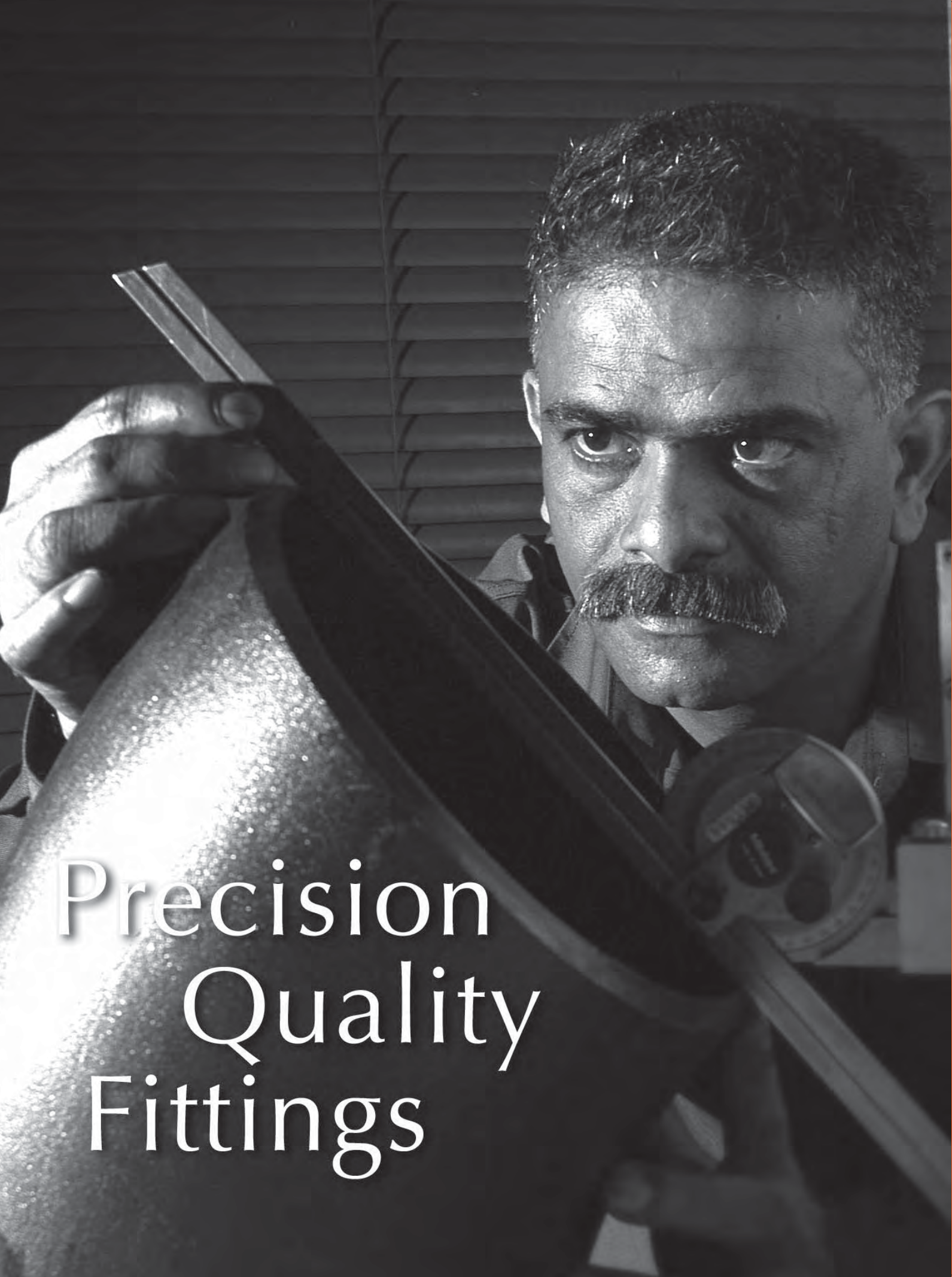

Precision
Quality
Fittings

Contents:

Product Catalogue

Carbon Steel Butt-Welded Fittings

2 The Organization



3 Range of Products



4 Technical Specifications

5 90° Elbow - Long Radius

6 90° Elbow - Short Radius

7 45° Elbow - Long Radius

8 180° Returns - Long Radius

9 Cap

10 Concentric Reducers

12 Equal and Reducing Tee

14 Production Process Flow



16 Experience the JAKS Difference



The Organization



JAKS Steel Industries Sdn. Bhd. - Fittings Division prides itself as one of Malaysia's leading manufacturers of carbon steel butt welded fittings trademarked 'WT'. The organization is guided by a vision, managed through careful planning that strives towards continuous improvements in technological innovations, adhering to strict quality control and serviced by efficient logistics support.

All these operational elements are integrated to produce excellence in quality products and customer service.

Operational quality assurance is constantly upgraded, with certification to internationally recognized standards such as ASTM, ASME and ISO 9001:2000. An efficient logistics network ensures timely delivery to clients locally and internationally. With an alliance of strategic global partners, the company is set to further enhance its business and future growth.



Range of Products

Carbon Steel Butt-Welded Fitting



90° Elbow - Long/Short Radius



45° Elbow - Long Radius



180° Returns - Long Radius



Cap



Concentric Reducers

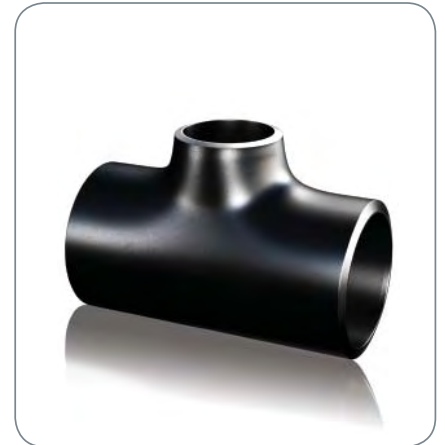

Equal and Reducing Tee

Our Quality Assurance

Strict adherence to quality controls enables the company to produce and provide excellent quality products and customer's satisfaction.



Quality management system is assessed and registered to the provisions of ISO 9001:2000. The company's operational standards are constantly upgraded and enhanced with a mission towards quality excellence through continuous improvement.



Technical Specifications

Carbon Steel Butt-Welded Fitting

90° Elbow - Long Radius

ASTM A234

ASME B16.9

Standard (STD) & Extra Heavy (XH)

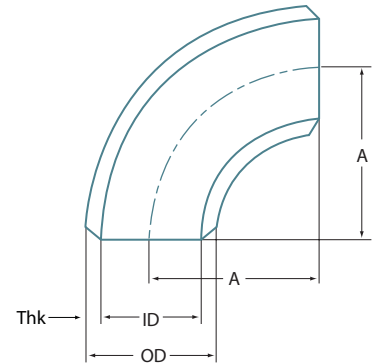

Nominal Pipe Size	Outside Diameter	STD		XH		Center to End	Approx. Unit Weight	
		ID (mm)	Thk (mm)	ID (mm)	Thk (mm)		STD (kg)	XH (kg)
1/2	21.3	15.8	2.77	-	-	38.1	0.08	-
3/4	26.7	20.9	2.87	-	-	38.1	0.11	-
1	33.5	26.8	3.38	-	-	38.1	0.16	-
1 1/4	42.2	35.0	3.56	32.5	4.85	47.8	0.26	0.35
1 1/2	48.3	40.9	3.68	38.1	5.08	57.2	0.37	0.50
2	60.5	52.6	3.91	49.4	5.54	76.2	0.66	0.90
2 1/2	73.2	62.8	5.16	59.1	7.01	95.3	1.29	1.79
3	88.9	77.9	5.49	73.7	7.62	114.3	2.04	2.74
4	114.3	102.3	6.02	97.2	8.56	152.4	3.84	5.36
5	141.2	128.1	6.55	-	-	190.5	6.48	-
6	168.1	153.9	7.11	-	-	228.6	9.94	-
8	218.9	202.6	8.18	193.5	12.70	304.8	20.10	30.50
10	273.1	254.5	9.27	247.7	12.70	381.0	35.40	47.70
12	323.9	304.8	9.52	298.5	12.70	457.2	52.00	68.70
14	355.6	336.6	9.52	330.2	12.70	533.4	67.90	89.90
16	406.4	387.4	9.52	381.0	12.70	609.6	89.00	118.00

90° Elbow - Short Radius

ASTM A234
ASME B16.9
Standard (STD)

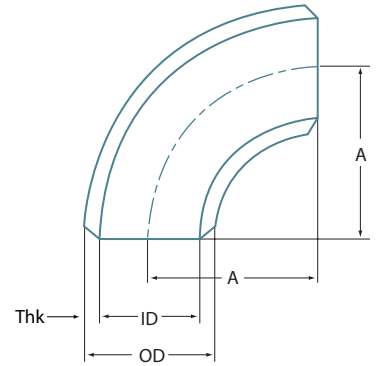

Nominal Pipe Size	Outside Diameter	STD		Center to End	Approx. Unit Weight
NPS (inch)	OD (mm)	ID (mm)	Thk (mm)	A (mm)	STD (kg)
2	60.5	52.6	3.91	50.8	0.44
2½	73.2	62.8	5.16	63.5	0.91
3	88.9	77.9	5.49	76.2	1.36
4	114.3	102.3	6.02	101.6	2.56
6	168.1	153.9	7.11	152.4	6.63
8	218.9	202.6	8.18	203.2	13.40
10	273.1	254.5	9.27	254.0	23.60
12	323.9	304.8	9.52	304.8	34.60
14	355.6	336.6	9.52	355.6	45.30
16	406.4	387.4	9.52	406.4	59.10

45° Elbow - Long Radius

ASTM A234

ASME B16.9

Standard (STD) & Extra Heavy (XH)

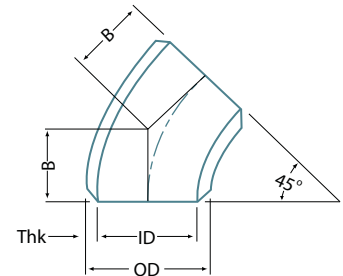

Nominal Pipe Size	Outside Diameter	STD		XH		Center to End	Approx. Unit Weight	
		ID (mm)	Thk (mm)	ID (mm)	Thk (mm)		STD (kg)	XH (kg)
2	60.5	52.6	3.91	49.4	5.54	35.1	0.33	0.45
2½	73.2	62.8	5.16	59.1	7.01	44.5	0.69	0.90
3	88.9	77.9	5.49	73.7	7.62	50.8	1.02	1.37
4	114.3	102.3	6.02	97.2	8.56	63.5	1.92	2.68
5	141.2	128.1	6.55	-	-	79.2	3.24	-
6	168.1	153.9	7.11	-	-	95.3	4.97	-
8	218.9	202.6	8.18	193.5	12.70	127.0	10.10	15.30
10	273.1	254.5	9.27	247.7	12.70	158.8	17.70	23.90
12	323.9	304.8	9.52	298.5	12.70	190.5	26.00	34.40
14	355.6	336.6	9.52	330.2	12.70	222.3	34.00	45.00
16	406.4	387.4	9.52	381.0	12.70	254.0	44.50	59.00

180° Returns - Long Radius

ASTM A234
ASME B16.9
Standard (STD)

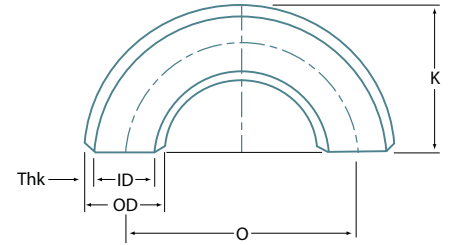

Nominal Pipe Size		Outside Diameter		STD		Center to Center	Back to Face	Approx. Unit Weight
NPS (inch)	OD (mm)	ID (mm)	Thk (mm)	O (mm)	K (mm)	STD (kg)		
2	60.5	52.6	3.91	152.4	106.4	1.30		
2½	73.2	62.8	5.16	190.5	131.8	2.58		
3	88.9	77.9	5.49	228.6	158.8	4.05		
4	114.3	102.3	6.02	304.8	209.6	7.69		

Cap

ASTM A234
ASME B16.9
Standard (STD)

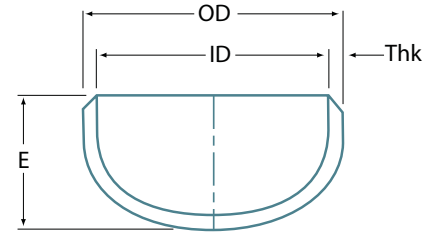

Nominal Pipe Size	Outside Diameter	STD		Length	Approx. Unit Weight
NPS (inch)	OD (mm)	ID (mm)	Thk (mm)	E (mm)	STD (kg)
1 ¹ / ₄	42.2	35.0	3.56	38.1	0.14
1 ¹ / ₂	48.3	40.9	3.68	38.1	0.17
2	60.5	52.6	3.91	38.1	0.24
2 ¹ / ₂	73.2	62.8	5.16	38.1	0.42
3	88.9	77.9	5.49	50.8	0.67
4	114.3	102.3	6.02	63.5	1.17
5	141.2	128.1	6.55	76.2	1.90
6	168.1	153.9	7.11	88.9	2.83

Concentric Reducers

ASTM A234
ASME B16.9
Standard (STD) & Extra Heavy (XH)

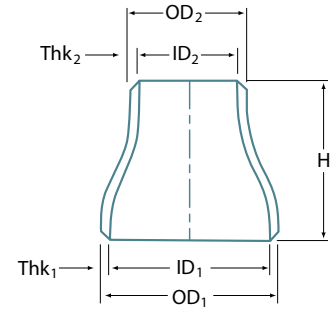

Nominal Pipe Size	Outside Diameter		STD				XH				End to End	Approx. Unit Weight	
	Large End	Small End	Large End		Small End		Large End		Small End			STD (kg)	XH (kg)
NPS (inch)	OD ₁ (mm)	OD ₂ (mm)	ID ₁ (mm)	Thk ₁ (mm)	ID ₂ (mm)	Thk ₂ (mm)	ID ₁ (mm)	Thk ₁ (mm)	ID ₂ (mm)	Thk ₂ (mm)	H (mm)	STD (kg)	XH (kg)
3/4 x 1/2	26.7	21.3	20.9	2.87	15.8	2.77	18.9	3.91	13.9	3.73	38.1	0.06	0.08
1 x 3/4	33.5	26.7	26.8	3.38	20.9	2.87	24.4	4.55	18.9	3.91	50.8	0.12	0.15
1 x 1/2	33.5	21.3	26.8	3.38	15.8	2.77	24.4	4.55	13.9	3.73	50.8	0.11	0.14
1 1/4 x 1	42.2	33.5	35.0	3.56	26.8	3.38	32.5	4.85	24.4	4.55	50.8	0.16	0.21
1 1/4 x 3/4	42.2	26.7	35.0	3.56	20.9	2.87	32.5	4.85	18.9	3.91	50.8	0.15	0.19
1 1/4 x 1/2	42.2	21.3	35.0	3.56	15.8	2.77	32.5	4.85	13.9	3.73	50.8	0.14	0.18
1 1/2 x 1 1/4	48.3	42.2	40.9	3.68	35.0	3.56	38.1	5.08	32.5	4.85	63.5	0.25	0.33
1 1/2 x 1	48.3	33.5	40.9	3.68	26.8	3.38	38.1	5.08	24.4	4.55	63.5	0.22	0.30
1 1/2 x 3/4	48.3	26.7	40.9	3.68	20.9	2.87	38.1	5.08	18.9	3.91	63.5	0.21	0.27
1 1/2 x 1/2	48.3	21.3	40.9	3.68	15.8	2.77	38.1	5.08	13.9	3.73	63.5	0.18	0.24
2 x 1 1/2	60.5	48.3	52.6	3.91	40.9	3.68	49.4	5.54	38.1	5.08	76.2	0.38	0.51
2 x 1 1/4	60.5	42.2	52.6	3.91	35.0	3.56	49.4	5.54	32.5	4.85	76.2	0.36	0.48
2 x 1	60.5	33.5	52.6	3.91	26.8	3.38	49.4	5.54	24.4	4.55	76.2	0.33	0.44
2 x 3/4	60.5	26.7	52.6	3.91	20.9	2.87	49.4	5.54	18.9	3.91	76.2	0.30	0.40
2 1/2 x 2	73.2	60.5	62.8	5.16	52.6	3.91	59.1	7.01	49.4	5.54	88.9	0.73	0.95
2 1/2 x 1 1/2	73.2	48.3	62.8	5.16	40.9	3.68	59.1	7.01	38.1	5.08	88.9	0.67	0.87
2 1/2 x 1 1/4	73.2	42.2	62.8	5.16	35.0	3.56	59.1	7.01	32.5	4.85	88.9	0.64	0.83
2 1/2 x 1	73.2	33.5	62.8	5.16	26.8	3.38	59.1	7.01	24.4	4.55	88.9	0.56	0.73
3 x 2 1/2	88.9	73.2	77.9	5.49	62.8	5.16	73.7	7.62	59.1	7.01	88.9	0.94	1.25
3 x 2	88.9	60.5	77.9	5.49	52.6	3.91	73.7	7.62	49.4	5.54	88.9	0.85	1.13
3 x 1 1/2	88.9	48.3	77.9	5.49	40.9	3.68	73.7	7.62	38.1	5.08	88.9	0.79	1.04

Concentric Reducers (cont')

ASTM A234

ASME B16.9

Standard (STD) & Extra Heavy (XH)

Nominal Pipe Size	Outside Diameter		STD				XH				End to End	Approx. Unit Weight	
	Large End	Small End	Large End		Small End		Large End		Small End			STD (kg)	XH (kg)
NPS (inch)	OD ₁ (mm)	OD ₂ (mm)	ID ₁ (mm)	Thk ₁ (mm)	ID ₂ (mm)	Thk ₂ (mm)	ID ₁ (mm)	Thk ₁ (mm)	ID ₂ (mm)	Thk ₂ (mm)	H (mm)	STD (kg)	XH (kg)
3 x 1 ¹ / ₄	88.9	42.2	77.9	5.49	35.0	3.56	73.7	7.62	32.5	4.85	88.9	0.75	1.00
3 x 1	88.9	33.5	77.9	5.49	26.8	3.38	73.7	7.62	24.4	4.55	88.9	0.71	0.96
4 x 3	114.3	88.9	102.3	6.02	77.9	5.49	97.2	8.56	73.7	7.62	101.6	1.45	2.02
4 x 2 ¹ / ₂	114.3	73.2	102.3	6.02	62.8	5.16	97.2	8.56	59.1	7.01	101.6	1.37	1.90
4 x 2	114.3	60.5	102.3	6.02	52.6	3.91	97.2	8.56	49.4	5.54	101.6	1.27	1.76
5 x 4	141.2	114.3	128.1	6.55	102.3	6.02	122.2	9.52	97.2	8.56	127.0	2.50	3.52
5 x 3	141.2	88.9	128.1	6.55	77.9	5.49	122.2	9.52	73.7	7.62	127.0	2.27	3.18
5 x 2 ¹ / ₂	141.2	73.2	128.1	6.55	62.8	5.16	-	-	-	-	127.0	2.16	-
5 x 2	141.2	60.5	128.1	6.55	52.6	3.91	-	-	-	-	127.0	2.03	-
6 x 5	168.1	141.2	153.9	7.11	128.1	6.55	146.2	10.97	122.2	9.52	139.7	3.57	5.38
6 x 4	168.1	114.3	153.9	7.11	102.3	6.02	146.2	10.97	97.2	8.56	139.7	3.30	4.96
6 x 3	168.1	88.9	153.9	7.11	77.9	5.49	146.2	10.97	73.7	7.62	139.7	3.04	4.56
6 x 2 ¹ / ₂	168.1	73.2	153.9	7.11	62.8	5.16	-	-	-	-	139.7	2.94	-
6 x 2	168.1	60.5	153.9	7.11	52.6	3.91	-	-	-	-	139.7	2.81	-
8 x 6	218.9	168.1	202.6	8.18	153.9	7.11	193.5	12.70	146.2	10.97	152.4	5.71	8.63
10 x 8	273.1	218.9	254.5	9.27	202.6	8.18	247.7	12.70	193.5	12.70	177.8	9.58	12.90

Equal & Reducing Tee

ASTM A234

ASME B16.9

Standard (STD) & Extra Heavy (XH)

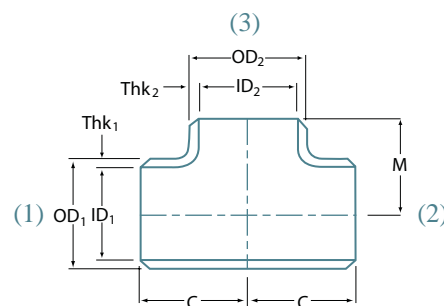

Nominal Pipe Size (1)x(2)x(3)	Outside Diameter		STD				XH				Center to End		Approx. Unit Weight	
			Run		Outlet		Run		Outlet		Run	Outlet	STD (kg)	XH (kg)
NPS (inch)	OD ₁ (mm)	OD ₂ (mm)	ID ₁ (mm)	Thk ₁ (mm)	ID ₂ (mm)	Thk ₂ (mm)	ID ₁ (mm)	Thk ₁ (mm)	ID ₂ (mm)	Thk ₂ (mm)	C (mm)	M (mm)	STD (kg)	XH (kg)
1/2 x 1/2 x 1/2	21.3	21.3	15.8	2.77	15.8	2.77	13.9	3.73	13.9	3.73	25.4	25.4	0.09	0.11
3/4 x 3/4 x 3/4	26.7	26.7	20.9	2.87	20.9	2.87	18.9	3.91	18.9	3.91	28.4	28.4	0.13	0.17
1 x 1 x 1	33.5	33.5	26.8	3.38	26.8	3.38	24.4	4.55	24.4	4.55	38.1	38.1	0.25	0.32
1 1/4 x 1 1/4 x 1 1/4	42.2	42.2	35.0	3.56	35.0	3.56	32.5	4.85	32.5	4.85	47.8	47.8	0.43	0.56
1 1/2 x 1 1/2 x 1 1/2	48.3	48.3	40.9	3.68	40.9	3.68	38.1	5.08	38.1	5.08	57.2	57.2	0.61	0.81
2 x 2 x 2	60.5	60.5	52.6	3.91	52.6	3.91	49.4	5.54	49.4	5.54	63.5	63.5	0.88	1.20
2 x 2 x 1	60.5	33.5	52.6	3.91	26.8	3.38	49.4	5.54	24.4	4.55	63.5	50.8	0.75	1.01
2 1/2 x 2 1/2 x 2 1/2	73.2	73.2	62.8	5.16	62.8	5.16	59.1	7.01	59.1	7.01	76.2	76.2	1.74	2.28
3 x 3 x 3	88.9	88.9	77.9	5.49	77.9	5.49	73.7	7.62	73.7	7.62	85.9	85.9	2.41	3.25
3 x 3 x 2	88.9	60.5	77.9	5.49	52.6	3.91	73.7	7.62	49.4	5.54	85.9	76.2	2.12	2.85
4 x 4 x 4	114.3	114.3	102.3	6.02	102.3	6.02	97.2	8.56	97.2	8.56	104.6	104.6	4.12	5.77
4 x 4 x 3	114.3	88.9	102.3	6.02	77.9	5.49	97.2	8.56	73.7	7.62	104.6	98.6	3.83	5.33
4 x 4 x 2 1/2	114.3	73.2	102.3	6.02	62.8	5.16	97.2	8.56	59.1	7.01	104.6	95.3	3.71	5.15
5 x 5 x 5	141.2	141.2	128.1	6.55	128.1	6.55	-	-	-	-	124.0	124.0	6.54	-
6 x 6 x 6	168.1	168.1	153.9	7.11	153.9	7.11	-	-	-	-	142.7	142.7	9.58	-
6 x 6 x 4	168.1	114.3	153.9	7.11	102.3	6.02	-	-	-	-	142.7	130.0	8.67	-
6 x 6 x 3	168.1	88.9	153.9	7.11	77.9	5.49	-	-	-	-	142.7	124.0	8.38	-

Precision Quality Fittings



Production Process Flow

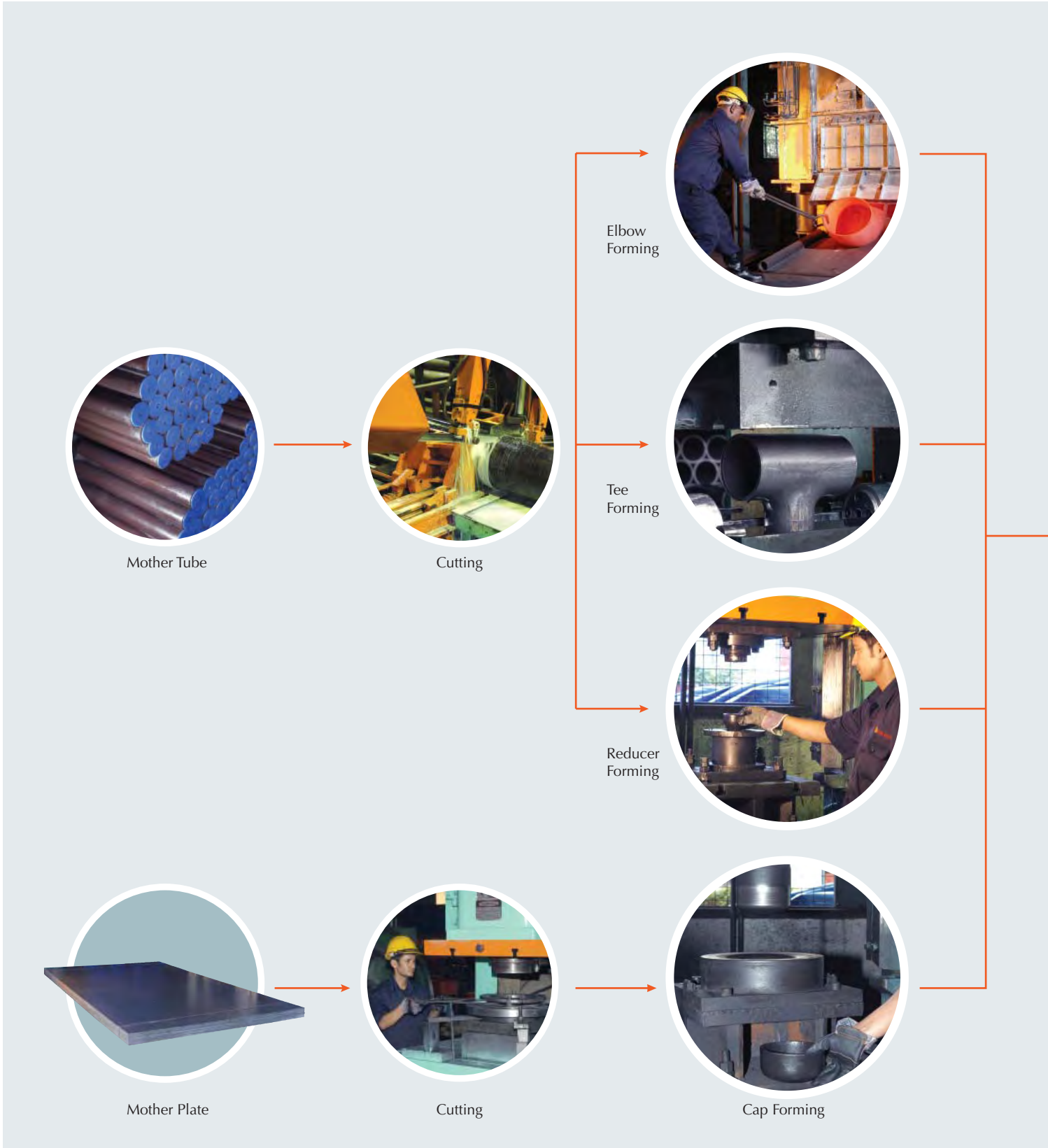

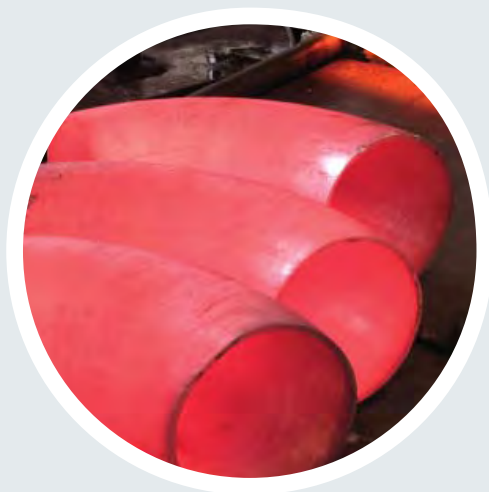

Annealing



Beveling



90° Elbow -
Long/Short Radius



45° Elbow -
Long Radius



180° Returns
- Long Radius



Equal &
Reducing Tee



Concentric
Reducers



Cap



Experience the JAKS Difference

There is not a single element that makes a business successful. It is a combination of attributes efficiently integrated that makes a business successful and sustainable.

To learn how JAKS Steel Industries can help service your needs and experience our difference, contact us with your inquiry.



Head Office and Manufacturing Facilities

JAKS STEEL INDUSTRIES SDN BHD (128652-U)

Lot 526, Persiaran Subang Permai
Sungai Penaga Industrial Park, USJ 1
47600 Subang Jaya, Selangor Darul Ehsan
Malaysia

Tel: 60 (3)-5633 1988

Fax: 60 (3)-5632 9828

North America Representative Office

1945 Montclair Avenue
Ottawa, Ontario K1W 1H9
Canada

Tel: 613-841 3743

Fax: 613-841 2305

For more info, visit our website at www.jaks.com.my

